

5 elements U- Yagi (ua9tc)

Designed by <http://www.hpsd.nl> (19sd348)

For: entire 11 meter band.

Antenna yagi type: UA9TC /Moxon

Boom length: 5,9 meter.

Gain: 9,5dBI (@27,555 MHz)

FB: < 30 dB

50 ohms impedance! NO MATCHING LOSS!

SWR below 1:1.1 over 1 Mhz !

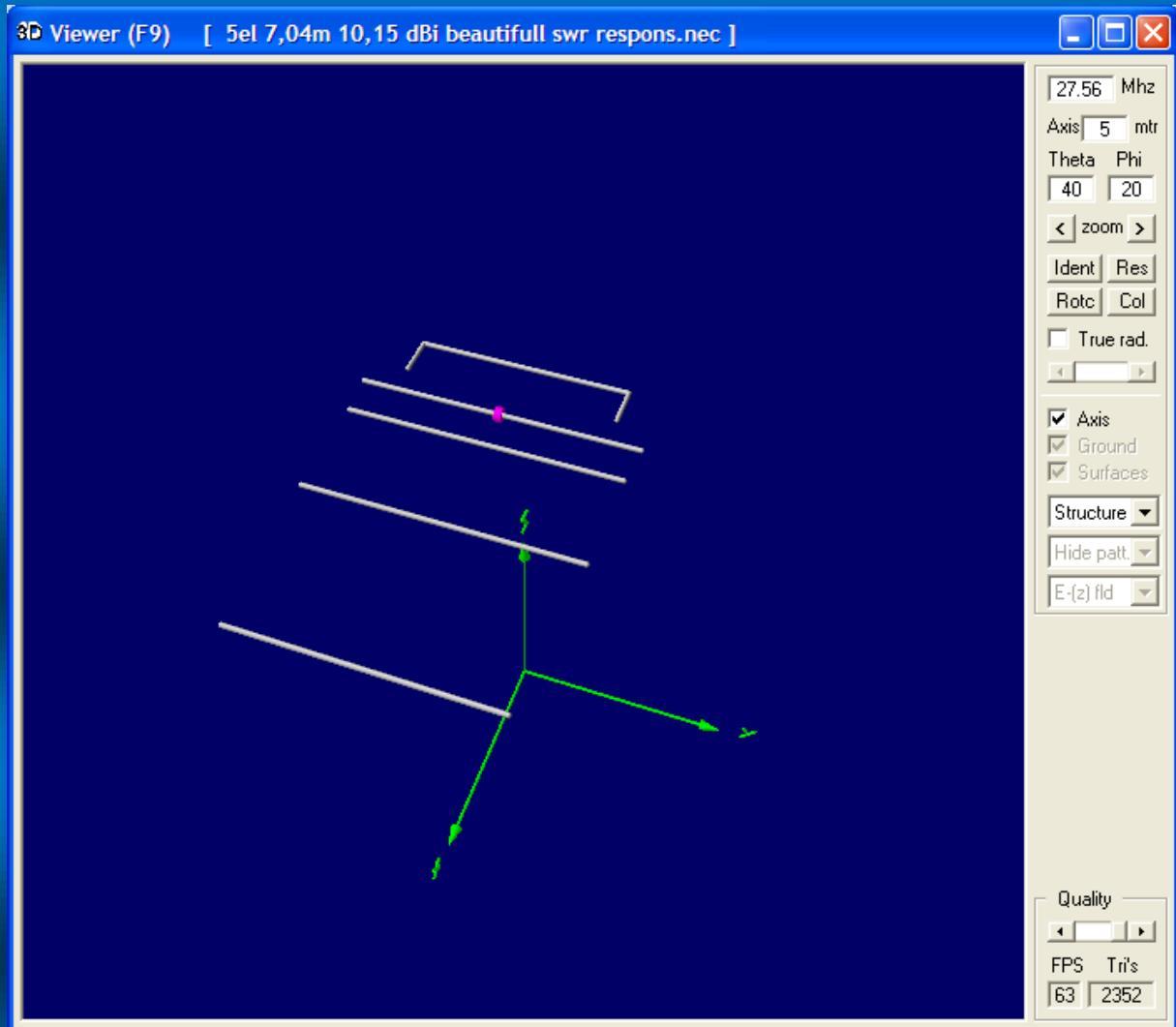

The end of the reflector is bend forward.
The pink “dot” indicates the feed point.

9,5 dBI Gain, front to back < 30 dB

5 elements U- Yagi (ua9tc)

Designed by <http://www.hpsd.nl> (19sd348)

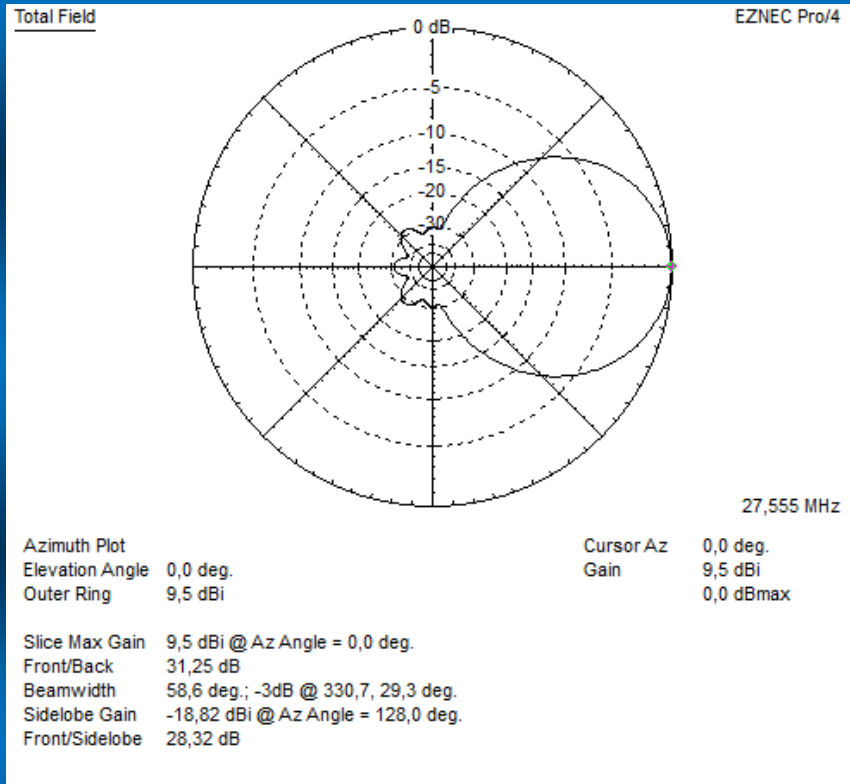

ABOVE THE AZIMUTH PLOT (HORIZONTAL PLANE)

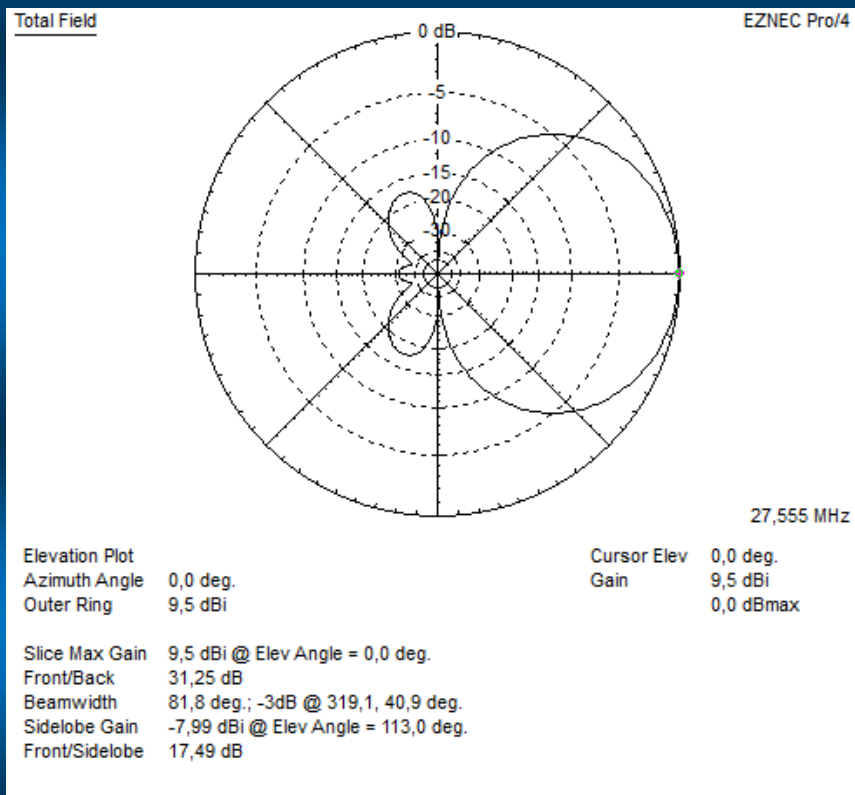

ABOVE THE ELEVATION PLOT (VERTICAL PLANE)

5 elements U- Yagi (ua9tc)

Designed by <http://www.hpsd.nl> (19sd348)

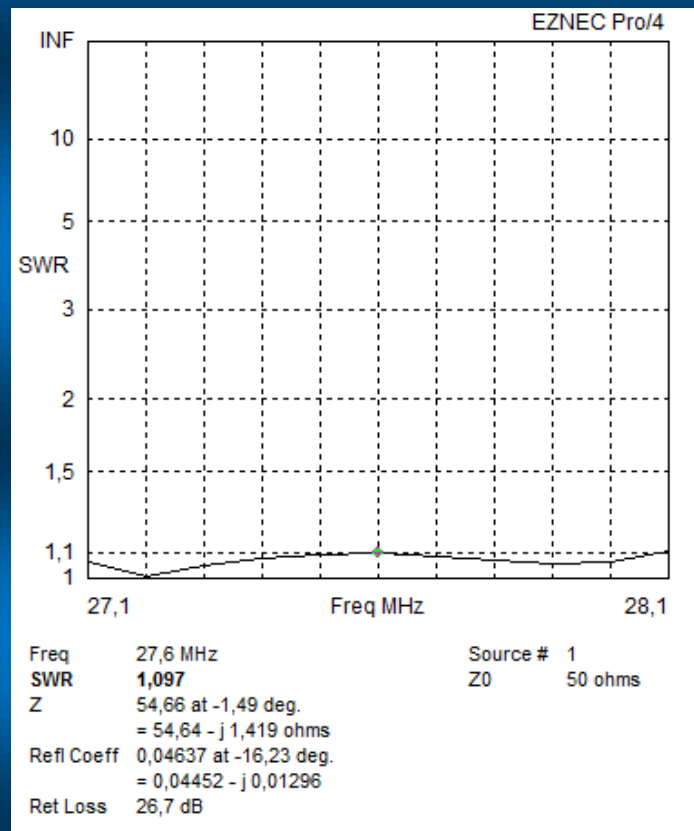

5 elements U- Yagi (ua9tc)

Designed by <http://www.hpsd.nl> (19sd348)

